



US008649842B2

(12) **United States Patent**  
**Atalar et al.**

(10) **Patent No.:** **US 8,649,842 B2**

(45) **Date of Patent:** **\*Feb. 11, 2014**

(54) **ELECTRICAL LEAD FOR AN ELECTRONIC DEVICE SUCH AS AN IMPLANTABLE DEVICE**

(58) **Field of Classification Search**  
USPC ..... 607/105, 116; 600/374  
See application file for complete search history.

(71) Applicants: **Boston Scientific Neuromodulation Corporation**, Valencia, CA (US); **MRI Interventions, Inc.**, Memphis, TN (US)

(56) **References Cited**

U.S. PATENT DOCUMENTS

2,130,758 A \* 9/1938 Rose ..... 607/155  
3,218,638 A \* 11/1965 Honig ..... 342/50

(Continued)

FOREIGN PATENT DOCUMENTS

WO WO-2004095281 A2 11/2004  
WO WO-2005114685 A1 12/2005

(Continued)

OTHER PUBLICATIONS

International Patent Application No. PCT/US06/17362, International Search Report and Written Opinion mailed Aug. 12, 2008.

(Continued)

*Primary Examiner* — Carl H Layno

*Assistant Examiner* — Jon Eric C Morales

(74) *Attorney, Agent, or Firm* — Frommer Lawrence & Haug LLP; Bruce E. Black

(21) Appl. No.: **13/741,009**

(22) Filed: **Jan. 14, 2013**

(65) **Prior Publication Data**

US 2013/0178924 A1 Jul. 11, 2013

**Related U.S. Application Data**

(60) Continuation of application No. 13/099,167, filed on May 2, 2011, now Pat. No. 8,380,277, which is a continuation of application No. 12/478,145, filed on Jun. 4, 2009, now Pat. No. 7,957,783, which is a division of application No. 11/417,594, filed on May 4, 2006, now Pat. No. 7,561,906.

(60) Provisional application No. 60/677,418, filed on May 4, 2005.

(51) **Int. Cl.**  
**A61B 5/04** (2006.01)

(52) **U.S. Cl.**  
USPC ..... **600/374; 607/116; 607/115**

(57) **ABSTRACT**

A lead for an electronic device which resists the induction of a current from an electromagnetic field external to said lead includes one or more pairs of adjacent segments of electrical wire, each of the pairs including a first segment of electrical wire and a second segment of electrical wire. The lead also includes one or more shielded RF chokes, wherein each of the shielded RF chokes is provided between the first segment of electrical wire and the second segment of electrical wire of a respective one of the one or more pairs of adjacent segments. Also, an implantable device that includes a generator for generating one or more electrical pulse and a lead as described for delivering the pulses to tissue within a patient's body. A method for making the described implantable device is also provided.

**20 Claims, 7 Drawing Sheets**

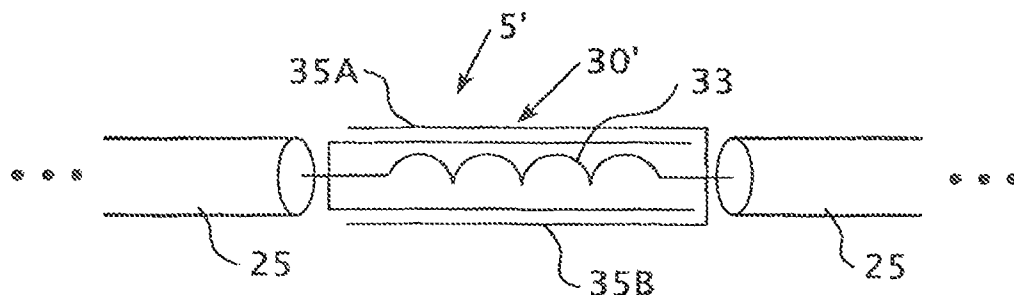

(56)

References Cited

U.S. PATENT DOCUMENTS

4,766,381 A 8/1988 Conturo et al.  
 5,246,438 A \* 9/1993 Langberg ..... 606/33  
 5,281,914 A 1/1994 Conturo et al.  
 5,314,458 A \* 5/1994 Najafi et al. .... 607/116  
 5,352,979 A 10/1994 Conturo  
 5,370,644 A \* 12/1994 Langberg ..... 606/33  
 6,188,219 B1 2/2001 Reeder et al.  
 6,284,971 B1 9/2001 Atalar et al.  
 6,408,202 B1 6/2002 Lima et al.  
 6,765,779 B2 7/2004 Stevenson et al.  
 6,765,780 B2 7/2004 Brendel et al.  
 6,888,715 B2 5/2005 Stevenson et al.  
 6,944,489 B2 9/2005 Zeijlemaker et al.  
 6,980,863 B2 12/2005 van Venrooij et al.  
 6,985,775 B2 1/2006 Reinke et al.  
 6,987,660 B2 1/2006 Stevenson et al.  
 7,012,192 B2 3/2006 Stevenson et al.  
 7,013,180 B2 3/2006 Dougherty et al.  
 7,015,393 B2 3/2006 Weiner et al.  
 7,035,076 B1 4/2006 Stevenson  
 7,035,077 B2 4/2006 Brendel  
 7,038,900 B2 5/2006 Stevenson et al.  
 7,136,273 B2 11/2006 Stevenson et al.  
 7,199,995 B2 4/2007 Stevenson  
 7,310,216 B2 12/2007 Stevenson et al.  
 7,489,495 B2 2/2009 Stevenson  
 7,535,693 B2 5/2009 Stevenson et al.  
 7,561,906 B2 \* 7/2009 Atalar et al. .... 600/374  
 7,623,335 B2 11/2009 Stevenson et al.  
 7,689,288 B2 3/2010 Stevenson et al.  
 7,751,903 B2 7/2010 Stevenson et al.  
 7,765,005 B2 7/2010 Stevenson  
 7,787,958 B2 8/2010 Stevenson  
 7,822,460 B2 10/2010 Halperin et al.  
 7,844,319 B2 11/2010 Susil et al.  
 7,853,324 B2 12/2010 Stevenson et al.  
 7,853,325 B2 12/2010 Dabney et al.  
 7,899,551 B2 3/2011 Westlund et al.  
 7,916,013 B2 3/2011 Stevenson  
 7,917,219 B2 3/2011 Stevenson et al.  
 7,957,783 B2 \* 6/2011 Atalar et al. .... 600/374  
 8,380,277 B2 \* 2/2013 Atalar et al. .... 600/374  
 2003/0179536 A1 9/2003 Stevenson et al.  
 2003/0213604 A1 11/2003 Stevenson et al.  
 2003/0213605 A1 11/2003 Brendel et al.  
 2004/0201947 A1 10/2004 Stevenson et al.  
 2004/0257747 A1 12/2004 Stevenson et al.  
 2004/0263174 A1 \* 12/2004 Gray et al. .... 324/322  
 2005/0007718 A1 1/2005 Stevenson et al.  
 2005/0190527 A1 9/2005 Stevenson et al.  
 2005/0201039 A1 9/2005 Stevenson et al.  
 2005/0219787 A1 10/2005 Stevenson et al.  
 2005/0247475 A1 11/2005 Stevenson et al.  
 2005/0248907 A1 11/2005 Stevenson et al.

2006/0028784 A1 2/2006 Brendel  
 2006/0085043 A1 4/2006 Stevenson  
 2006/0212096 A1 9/2006 Stevenson  
 2006/0221543 A1 10/2006 Stevenson et al.  
 2007/0019362 A1 1/2007 Stevenson et al.  
 2007/0035910 A1 2/2007 Stevenson  
 2007/0112398 A1 5/2007 Stevenson et al.  
 2007/0123949 A1 5/2007 Dabney et al.  
 2007/0288058 A1 12/2007 Halperin et al.  
 2008/0049376 A1 2/2008 Stevenson et al.  
 2008/0065181 A1 3/2008 Stevenson  
 2008/0071313 A1 3/2008 Stevenson et al.  
 2008/0116997 A1 5/2008 Dabney et al.  
 2008/0119919 A1 5/2008 Atalar et al.  
 2008/0132987 A1 6/2008 Westlund et al.  
 2008/0269591 A1 10/2008 Halperin et al.  
 2009/0116167 A1 5/2009 Stevenson et al.  
 2009/0259265 A1 10/2009 Stevenson et al.  
 2010/0016936 A1 1/2010 Stevenson et al.  
 2010/0023000 A1 1/2010 Stevenson et al.  
 2010/0023095 A1 1/2010 Stevenson et al.  
 2010/0060431 A1 3/2010 Stevenson et al.  
 2010/0160997 A1 6/2010 Johnson et al.  
 2010/0168821 A1 7/2010 Johnson et al.  
 2010/0174349 A1 7/2010 Stevenson et al.  
 2010/0191236 A1 7/2010 Johnson et al.  
 2010/0191306 A1 7/2010 Stevenson et al.  
 2010/0194541 A1 8/2010 Stevenson et al.  
 2010/0198312 A1 8/2010 Stevenson et al.  
 2010/0217262 A1 8/2010 Stevenson et al.  
 2010/0222857 A1 9/2010 Halperin et al.  
 2010/0280584 A1 11/2010 Johnson et al.  
 2010/0321163 A1 12/2010 Stevenson  
 2010/0324639 A1 12/2010 Stevenson et al.  
 2011/0001610 A1 1/2011 Stevenson et al.  
 2011/0022140 A1 1/2011 Stevenson et al.  
 2011/0040343 A1 2/2011 Johnson et al.  
 2011/0054582 A1 3/2011 Dabney et al.  
 2011/0066212 A1 3/2011 Stevenson et al.  
 2011/0218422 A1 9/2011 Atalar et al.

FOREIGN PATENT DOCUMENTS

WO WO-2007102893 A2 9/2007  
 WO WO-2007117302 A2 10/2007

OTHER PUBLICATIONS

U.S. Appl. No. 12/478,145, Official Communication mailed Jun. 7, 2010.  
 U.S. Appl. No. 12/478,145, Official Communication mailed Oct. 28, 2010.  
 U.S. Appl. No. 12/478,145, Official Communication mailed Jan. 26, 2011.  
 U.S. Appl. No. 13/099,167, Official Communication mailed Aug. 23, 2012.

\* cited by examiner

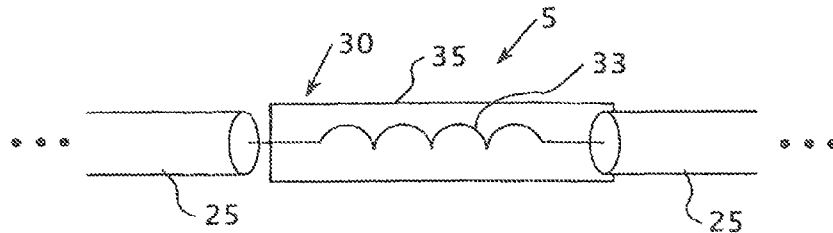

FIG. 1

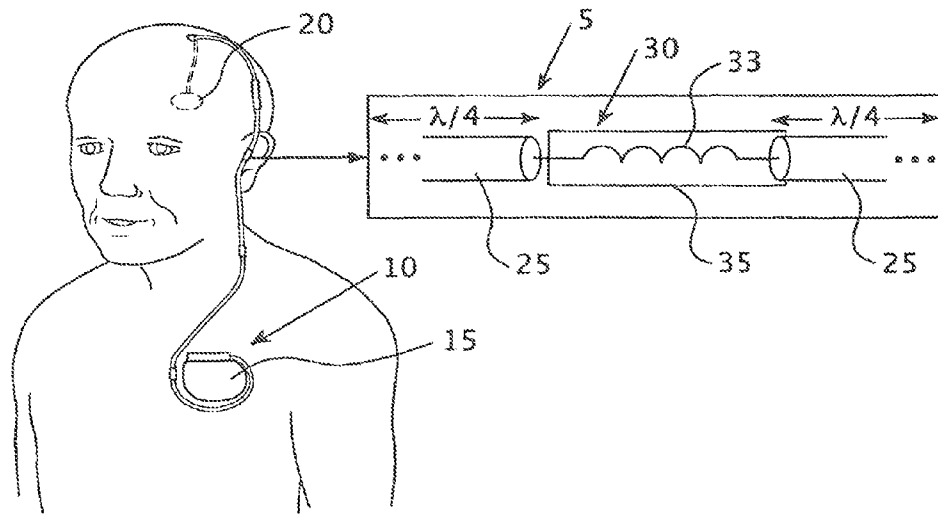

FIG. 2

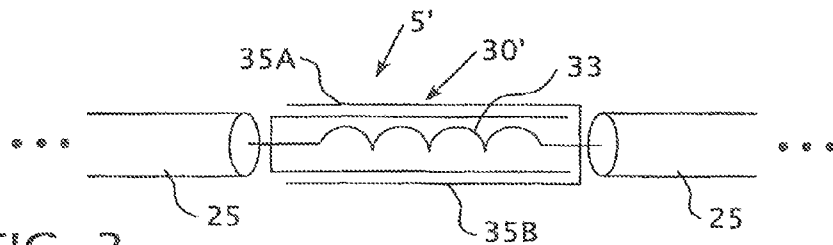

FIG. 3

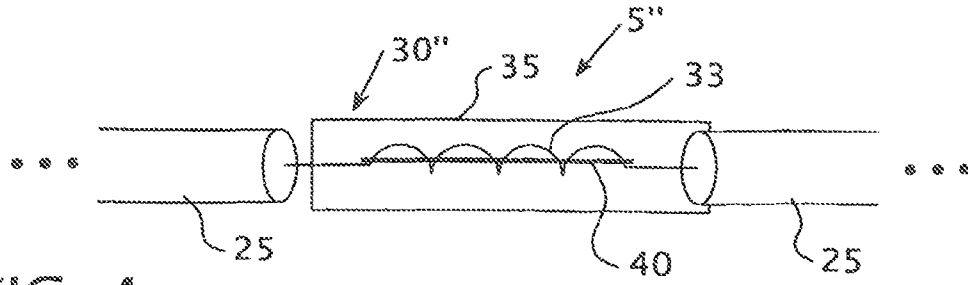

FIG. 4

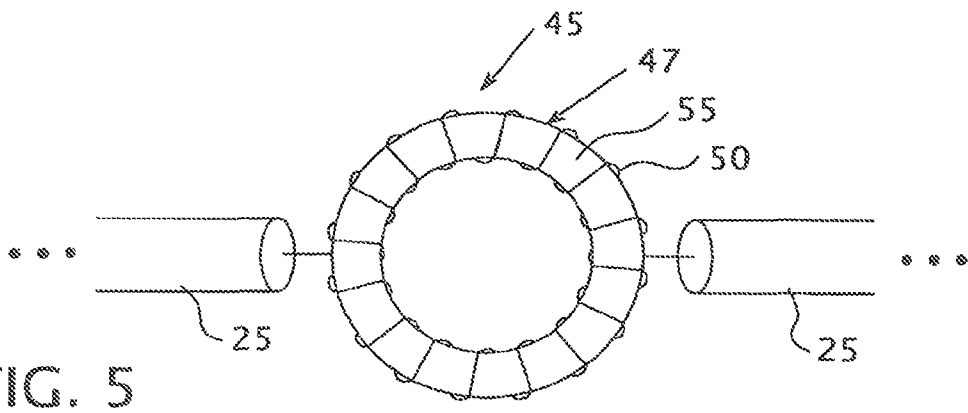

FIG. 5

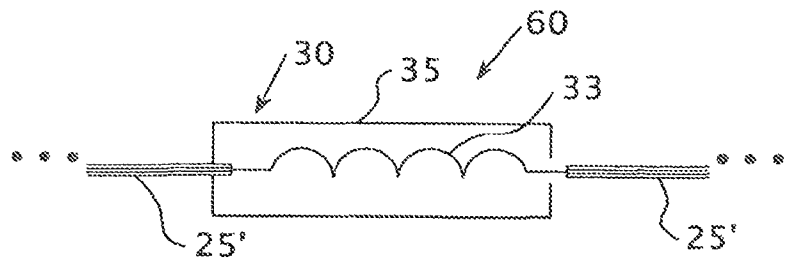

FIG. 6A

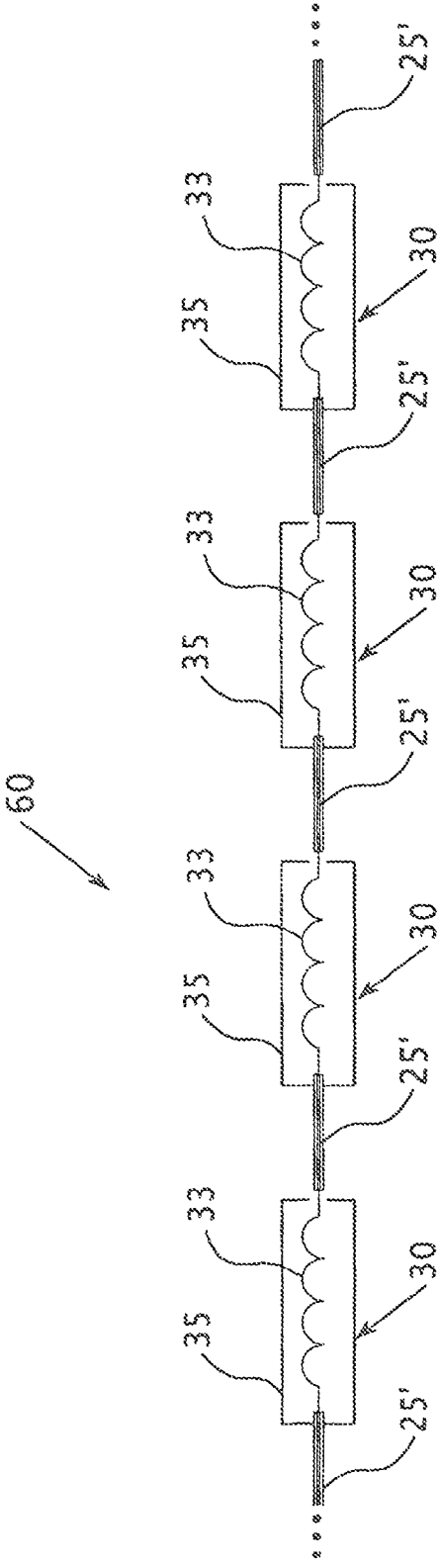

FIG. 6B

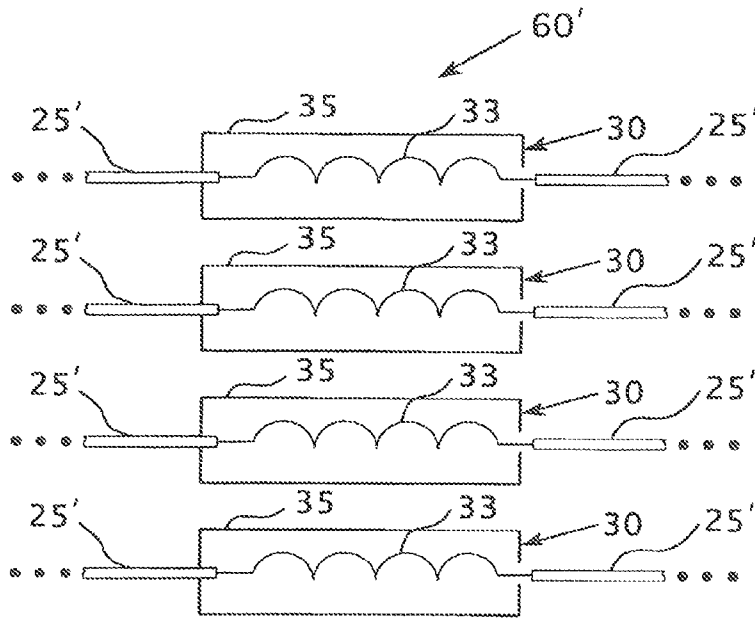

FIG. 7

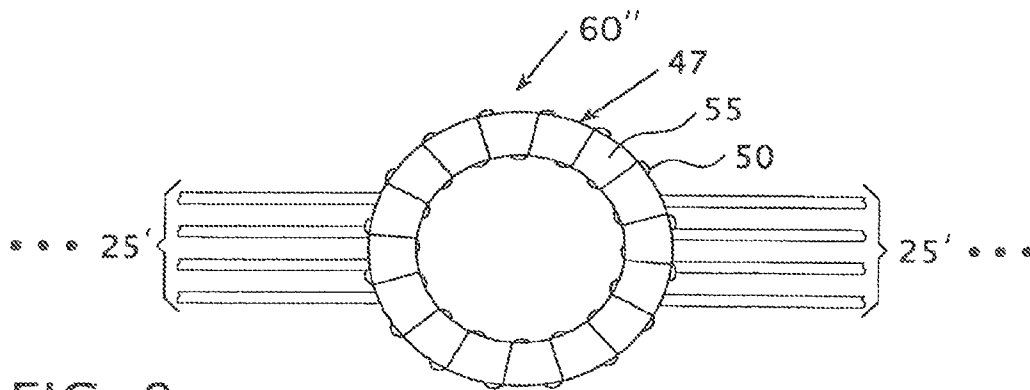

FIG. 8

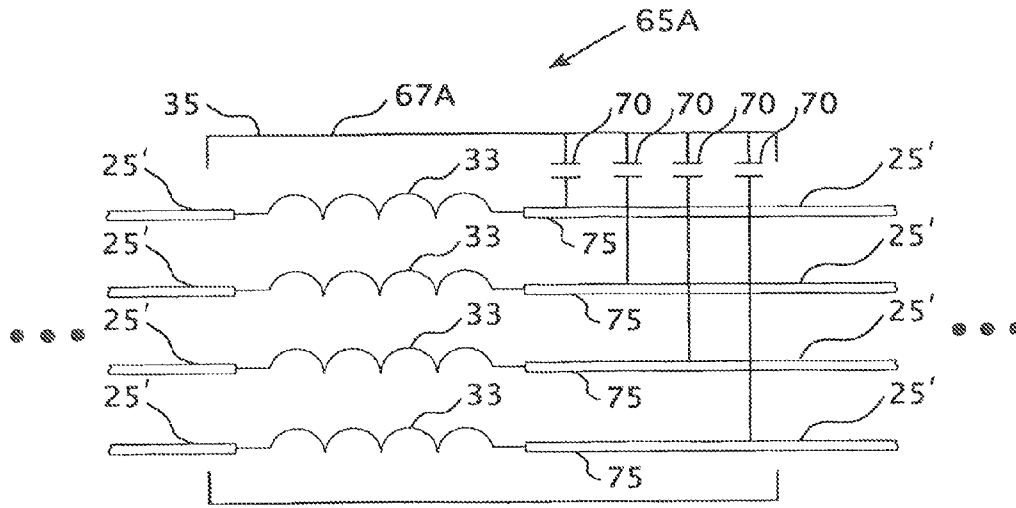

FIG. 9A

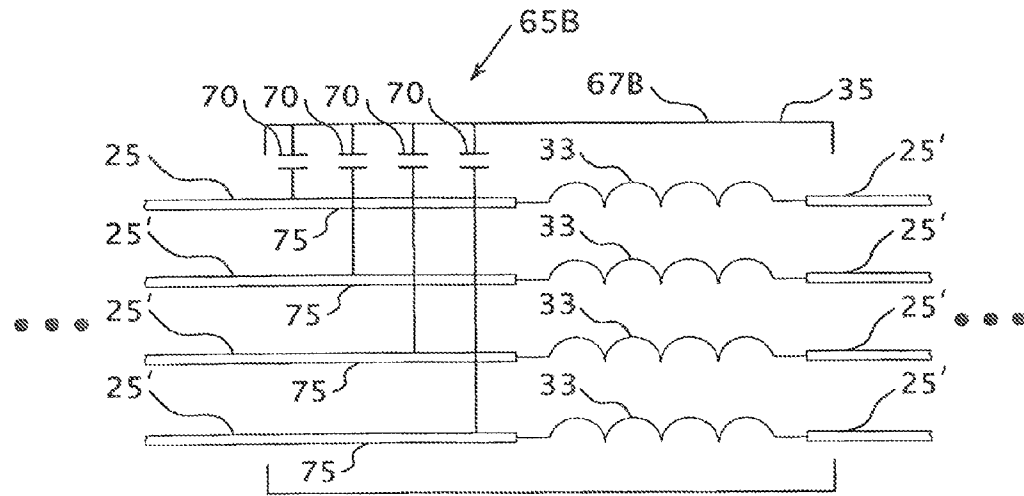

FIG. 9B

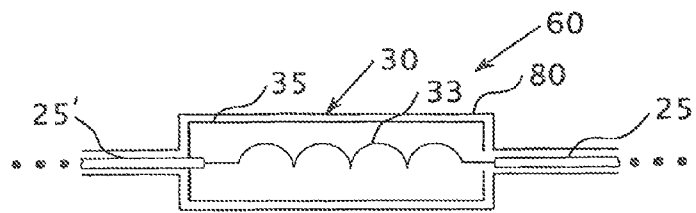

FIG. 10

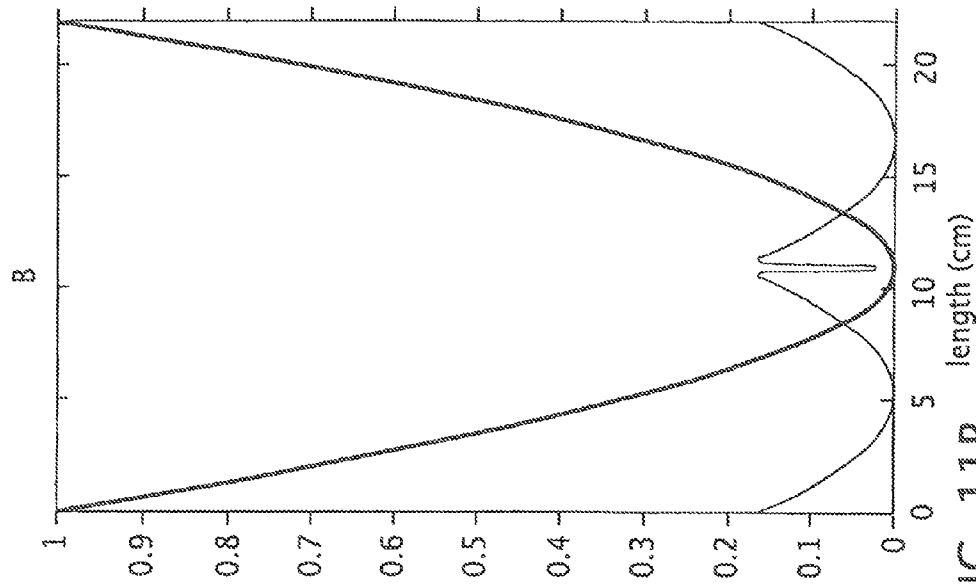

FIG. 11A

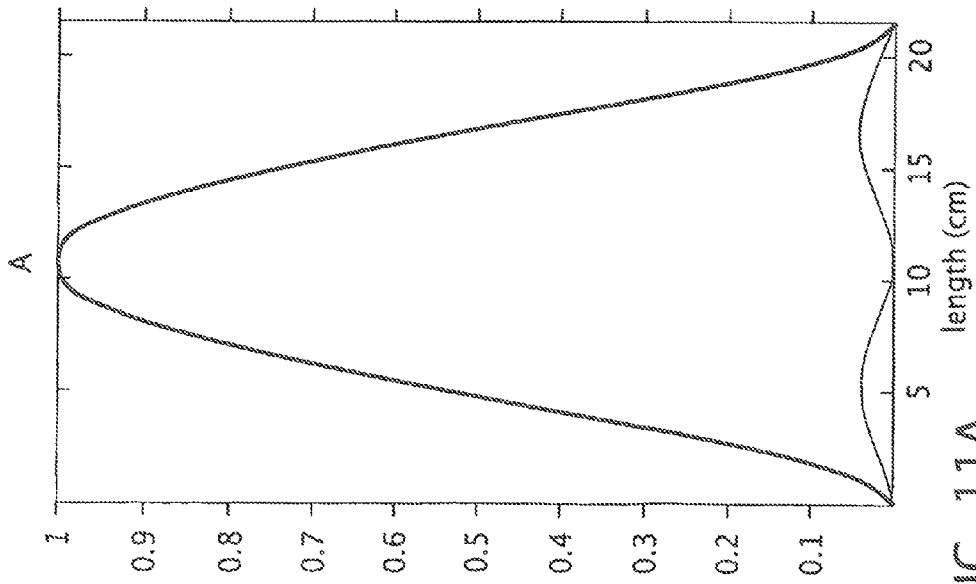

FIG. 11B



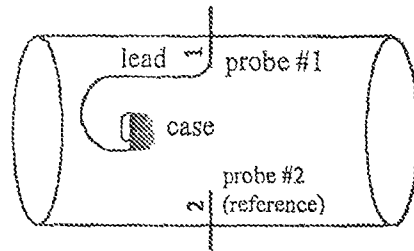

Fig. 12

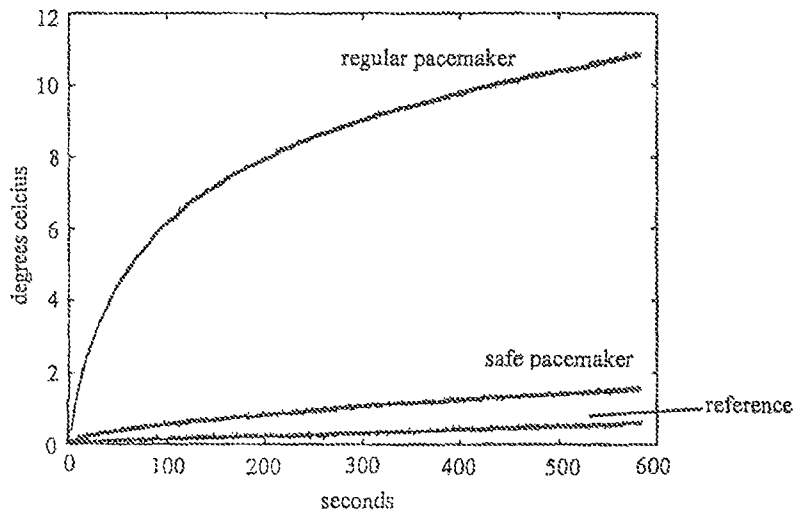

Fig. 13

## ELECTRICAL LEAD FOR AN ELECTRONIC DEVICE SUCH AS AN IMPLANTABLE DEVICE

### CROSS-REFERENCE TO RELATED APPLICATION

This application is a Continuation of U.S. patent application Ser. No. 13/099,167 filed May 2, 2011, is now U.S. Pat. No. 8,380,277, which is a Continuation of U.S. patent application Ser. No. 12/478,145 filed Jun. 4, 2009, now U.S. Pat. No. 7,957,783, which is a Divisional of U.S. patent application Ser. No. 11/417,594 filed May 4, 2006, now U.S. Pat. No. 7,561,906, which claims the benefit of U.S. Provisional Application No. 60/677,418, which was filed on May 4, 2005, all of which are incorporated herein by reference.

### FIELD OF THE INVENTION

The present invention relates to electrical leads for devices such as, without limitation, implantable devices, and in particular to an electrical lead which resists the induction of currents from an external electromagnetic field and therefore reduces the likelihood of excessive heating from such fields.

### BACKGROUND OF THE INVENTION

Magnetic resonance imaging (MRI) is generally regarded as an extremely safe, non invasive diagnostic technique. MRI may, however, pose a threat to patients that have implantable devices, such as, without limitation, a deep brain stimulation (DBS) device, a pacemaker, a neurostimulator, or a cardio defibrillator. Currently, patients with metallic implants are not allowed to undergo an MRI scan. One of the main reasons for this is the excessive heating caused by the electromagnetic field concentration around the leads of an implant during an MM procedure.

Many cases with substantial temperature increase during MM scanning have been reported and reviewed. For example, in Achenbach S, Moshage W, Diem B, Bieberle T, Schibgilla V, Bachmann K., "Effects of Magnetic Resonance imaging on Cardiac Pacemakers and Electrodes," *Am Heart J* 1997; 134:467-473, a maximum temperature increase of 63.1° C. was reported during 90 seconds of MRI scanning. Additionally, in an in vitro evaluation of 44 commercially available pacemaker leads, it was reported in Sommer T, Hahlhaus C, Lauck G, et al., "MR Imaging and Cardiac Pacemakers: In Vitro Evaluation and In Vivo Studies in 51 patients at 0.5 T.," *Radiology* 2000; 215:869-879, that a temperature increase of 23.5° C. was observed in a 0.5 Tesla experiment. Substantial temperature increases were also observed in MRI scans involving patients with neurostimulators, as reported in Gleason C A, Kaula N F, Hricak H, et al., "The Effect of Magnetic Resonance Imagers on Neurostimulators," *Pacing Clin Electrophysiol* 1992; 15: 8-94. Furthermore, 1.5 T and a SAR of 3.0 W/kg have been shown to cause severe necrosis in the mucous membranes of dogs with transesophageal cardiac pacing leads as reported in Hofman M B, de Cock C C, van der Linden J C, et al., "Transesophageal Cardiac Pacing During Magnetic Resonance Imaging: Feasibility And Safety Considerations," *Magn Reson Med* 1996; 35:413-422.

Moreover, a 16.8° C. temperature increase on a half wavelength wire in a gel-phantom experiment was observed and reported in Smith C D, Kildishev A V, Nyenhuis J A, Foster K S, Bourland J D, "Interactions Of MRI Magnetic Fields With Elongated Medical Implants," *J Applied Physics* 2000; 87:6188-6190. As reported in Konings M K, Bartels L W,

Smits H J, Bakker C J, "Heating Around Intravascular Guidewires By Resonating RF Waves," *J Magn Reson imaging* 2000; 12:79-85, temperature increases due to endovascular guidewires between 26° C. and 74° C. were observed in saline bath experiments of up to 30 seconds of scan time. In another experiment with saline solution, reported in Nitz W R, Oppelt A, Renz W, Manke C, Leniart M, Link J., "On The Heating Of Linear Conductive Structures As Guide Wires And Catheters In Interventional MRI," *J Magn Reson Imaging* 2001; 13:105-114, up to 34° C. of temperature increase was observed for a half wavelength wire. It should be noted that first, second or third order burns were observed in many of the in-vivo studies mentioned above.

A recent study was performed for one of the most widely used neurostimulation systems, the Activa Tremor Control System sold by Medtronic. Different configurations were evaluated to assess worst case and clinically relevant positioning scenarios, and in vitro experiments were performed at 64 MHz MR system using get phantoms to represent human tissue. As reported in Rezai A R, Finelli D, Nyenhuis J A, et al., "Neurostimulator For Deep Brain Stimulation: Ex Vivo Evaluation Of MRI-Related Heating At 1.5-Tesla," *J Magn Reson Imaging* 2002; 15:241-250, the highest temperature change observed was 25.3° C. for the RF coil and 7.1° C. for the head coil. These results indicate that heating may be hazardous under certain MRI scanning conditions.

The FREEHAND System Implantable Functional Neurostimulator is a commercially available RF-powered motor control neuroprosthesis that consists of both implanted and external components sold by NeuroControl Corporation of Cleveland, Ohio, Findings from of an MRI-induced heating experiment during which the FREEHAND System was exposed to a whole-body-averaged SAR of 1.1 W/kg for 30 minutes showed that localized temperature increases were no greater than 2.7° C. with the device in a gel-titled phantom. A patient with a FREEHAND system can thus only undergo an MRI procedure under certain input power levels for a 1.5 Tesla scanner.

Due to the safety concerns created by the potential for excessive heating as described above, several strategies have been developed to promote MRI safety for patient's having metallic implants. One of the basic ones is to set a power threshold that ensures only a reasonable amount of heating will occur. A methodology for such a power limitation was previously published in Yeung C J, Susil R C, Atalar K E., "RF Safety Of Wires In Interventional MRI: Using A Safety index," *Magn Reson Med* 2002; 47:187-193. However, many modern MRI pulse sequences, such as fast spin-echo or steady-state free precession (SSFP), require high RF power levels and therefore there is no guarantee that good quality images can be acquired if RF power is limited.

Most of the studies on the heating of metallic implants concentrate on the heating of the leads of the implant rather than the generator of the implant. This is primarily due to the fact that generators are typically smooth devices with curved edges and are therefore less threatening structures than the leads in terms of electromagnetic field concentration. As a result, less heating is observed and smaller temperature increase is expected in generators. See, for example, the results reported in Ferhanoglu O, Tasci O. T, El-Sharkawy A, Altintas A, Atalar E, "Investigating RF Heating Of Pacemakers In MRI Using A Safety Index", *Proc. International Society of Magnetic Resonance in Medicine, 12<sup>th</sup> Scientific Meeting, Kyoto, 2004*, and Ferhanoglu O, El-Sharkawy A, Atalar E, "RF Heating At The Tip Of Pacemaker Leads," *Proc. European Society of Magnetic Resonance in Medicine and Biology, 21<sup>st</sup>; Scientific Meeting, Copenhagen, 2004*.

U.S. Pat. No. 6,284,971 discloses a coaxial cable which may be a magnetic resonance imaging coaxial cable designed for enhanced safety so as to reduce the risk of excessive heating or burns to a user. The cable has an elongated axially oriented inner conductor and an axially oriented outer shield conductor in spaced relationship with respect thereto with a first dielectric material disposed therebetween. However in this design, high permittivity materials must be employed. This requirement may create flexibility problems since high permittivity materials are brittle and rigid. In addition, there may be more than one the lead which may require usage of separate coaxial cables. In such a case, miniaturization of the design is a difficult task.

RF chokes and filters have been used in several previous studies. For example, as described in Susil R C, et al., "Multifunctional Interventional Devices for MRI: A Combined Electrophysiology/MRI Catheter", MRM 47:594-600 (2002), RF chokes were used in the design of a combined electrophysiology/MRI catheter, and as described in Ladd M E, et al., "Reduction of Resonant RF Heating in Intravascular Catheters Using Coaxial Chokes", MRM 43:615-619 (2000), triaxial chokes were used to present a high impedance to currents flowing on the outer surface of the triax.

U.S. Pat. No. 6,539,253 discloses an implantable medical device incorporating integrated circuit notch filters, and U.S. Pat. No. 5,817,136 discloses a pacemaker with EMI protection. Both of the designs ensure electromagnetic interference is not a problem, however safety in terms of heating is not guaranteed. High current may still be flowing through long cables and these high currents may cause excessive heating and burns.

U.S. Pat. No. 5,217,010 describes optical signal transmission in between the generator and the organ in a pacemaker, which provides safety since there is no coupling with the optical system and the electromagnetic field. However, the electrical to optical and optical to electrical energy conversion efficiency is limited and therefore the lifetime of the pulse generator is reduced significantly. Miniaturization in this case is also a difficult task.

It is thus apparent that a need exists for an electrical lead which may be used with, for example, metallic implants, which resists the induction of currents from an external electromagnetic field, such as the field that is present during MRI scanning, and therefore reduces the likelihood of excessive heating from such fields.

#### SUMMARY OF THE INVENTION

In one embodiment, the invention relates to lead for an electronic device which resists the induction of a current from an electromagnetic field external to the lead, as may be present during an MRI process. The lead includes one or more pairs of adjacent segments of electrical wire, each of the pairs including a first segment of electrical wire and a second segment of electrical wire. The adjacent segments of electrical wire may be single conductor electrical wires or multiple conductor electrical wires. The lead also includes one or more shielded RF chokes, wherein each of the shielded RF chokes is provided between the first segment of electrical wire and the second segment of electrical wire of a respective one of the one or more pairs of adjacent segments. The shielded RF chokes have a first end operatively coupled to the first segment of electrical wire and a second end operatively coupled to the second segment of electrical wire of the respective pair of adjacent segments. Preferably, the one or more pairs of adjacent segments comprises a plurality of pairs of adjacent

segments of electrical wire and the one or more shielded RF chokes comprises a plurality of shielded RF chokes.

In one particular embodiment, the electromagnetic field includes electromagnetic energy having a first wavelength, and the first segment of electrical wire and the second segment of electrical wire in each of the plurality of pairs of adjacent segments of electrical wire each has a length of no more than about a predetermined percentage, such as twenty five percent, of the first wavelength. The electronic device may be a device carried by the body of a patient, such as an implantable device.

The shielded RF chokes may include an inductor covered by one or more layers of conductive shielding material, such as a metallic shielding material. Preferably, a first end of the one or more layers of conductive shielding material is electrically connected to the inductor and a second end of the one or more layers of conductive shielding material is either floating or connected to an insulator. In addition, each inductor in the shielded RF chokes may include a core, such as a paramagnetic core. Alternatively, the shielded RF chokes may comprise toroidal inductors, wherein a coil is wrapped around a doughnut-shaped core. Additionally, one or more electrical shielding layers, such as metallic layers, may be provided around the toroidal inductor to provide additional shielding.

In another embodiment, the lead may further include a layer of insulating material covering at least a portion of the one or more pairs of adjacent segments of electrical wire and at least a portion the one or more shielded RF chokes.

In one particular embodiment, one or more of the one or more shielded RF chokes comprises a first conductor and a first inductor connected in series and provided between the first segment of electrical wire and the second segment of electrical wire of the respective one of the one or more pairs of adjacent segments, at least one layer of conductive shielding material covering the first conductor and the first inductor, and a capacitor provided between the first conductor and the at least one layer of conductive shielding material.

In yet another embodiment, the invention relates to an apparatus that may be implanted within a patient's body which resists the induction of a current from an electromagnetic field external to the apparatus. The apparatus includes a generator for generating one or more electrical pulses, and a lead for delivering the one or more electrical pulses to tissue within the patient's body. The lead in the apparatus may be structured according to the various embodiments described above.

In still a further embodiment, the invention relates to a method of making an implantable device including the various embodiments of the lead described above. In particular, the method includes providing one or more pairs of adjacent segments of electrical wire, each of the pairs including a first segment of electrical wire and a second segment of electrical wire, and providing a shielded RF choke, as described in the various embodiments above, between the first segment of electrical wire and the second segment of electrical wire of each one of the one or more pairs of adjacent segments.

#### BRIEF DESCRIPTION OF THE DRAWINGS

The accompanying drawings illustrate presently preferred embodiments of the invention, and together with the general description given above and the detailed description given below, serve to explain the principles of the invention. As shown throughout the drawings, like reference numerals designate like or corresponding parts.

FIG. 1 is a schematic diagram of an electrical lead according to a first embodiment of the present invention;

FIG. 2 is a schematic diagram showing the electrical lead of FIG. 1 being used in an implantable device;

FIG. 3 is a schematic diagram of a first embodiment of an electrical lead according to the present invention;

FIG. 4 is a schematic diagram of a second embodiment of an electrical lead according to the present invention;

FIG. 5 is a schematic diagram of a third embodiment of an electrical lead according to the present invention;

FIG. 6A is a schematic diagram of a fourth embodiment of an electrical lead according to the present invention;

FIG. 6B is a schematic diagram of a fifth embodiment of an electrical lead according to the present invention;

FIG. 7 is a schematic diagram of a sixth embodiment of an electrical lead according to the present invention;

FIG. 8 is a schematic diagram of a seventh embodiment of an electrical lead according to the present invention;

FIG. 9A is a schematic diagram of an eighth embodiment of an electrical lead according to the present invention;

FIG. 9B is a schematic diagram of a ninth embodiment of an electrical lead according to the present invention;

FIG. 10 is a schematic diagram of a tenth embodiment of an electrical lead according to the present invention;

FIG. 11A shows normalized induced current on a regular wire and a lead according to an embodiment of the invention;

FIG. 11B shows the SAR distribution on the surface of the regular wire and the lead according to an embodiment of the invention;

FIG. 12 shows a set up for a gel phantom experiment that was performed on a pacemaker including an electrical lead according to an embodiment of the invention; and

FIG. 13 shows temperature profiles of the gel phantom experiments performed on a pacemaker including an electrical lead according to an embodiment of the invention.

#### DESCRIPTION OF THE PREFERRED EMBODIMENTS

FIG. 1 is a schematic diagram of an electrical lead 5 for an electronic device carried by the body of a patient according to a first embodiment of the present invention. As used herein, the term "patient" shall refer to any member of the animal kingdom, including human beings. As used herein, the terms "carried by the body of the patient" in reference to as device shall mean that the device may be implanted within the patient body, worn on or attached externally to the patient's body, or some combination thereof. In the preferred embodiment, as shown schematically in FIG. 2, the electrical lead 5 shown in FIG. 1 forms a part of an implantable device 10, such as, without limitation, a deep brain stimulation (DBS) device, a pacemaker, a neurostimulator, or a cardio defibrillator, to deliver electrical signals (e.g., electrical pulses) from a generator 15 to a location 20, such as an organ or some other tissue, within the body to which the electrical signals are to be applied (for illustrative purposes, FIG. 2 shows a DBS device). As described in greater detail herein, the electrical lead 5 allows for safer MRI scanning of patients by decreasing the amount of heating caused by the RF field.

Referring again to FIG. 1, the electrical lead 5 includes a plurality of segments of electrical wire 25 which, in this embodiment, each comprise a single conductor wire. Preferably, each of the segments of electrical wire 25 comprises a flexible insulated single conductor wire. As seen in FIG. 1, the electrical lead 5 includes a shielded RF choke 30 that is inserted between two adjacent segments of electrical wire 25. As used herein, the term "shielded RF choke" shall refer to an inductor that traps an electromagnetic field or fields within a confined area in order to resist the penetration of external

electromagnetic fields into the confined area and therefore resist interaction between external electromagnetic fields and with electromagnetic fields that may exist in the confined area.

In the embodiment shown in FIG. 1, the shielded RF choke 30 comprises an inductor 33, in the form of a coil, surrounded by a layer of electrical shielding material 35, such as a metallic shielding material like copper, aluminum, gold, silver or nitinol. The layer of shielding material 35 helps to reduce the risk of magnetic coupling during an MRI scanning process. As seen in FIG. 1, a first end of the inductor 33 is electrically coupled to one of the adjacent segments of electrical wire 25 and the opposite end of the inductor 33 is electrically coupled to the other of the adjacent segments of electrical wire 25. In addition, one end of the layer of conductive shielding material 35 is electrically connected to the inductor 33 and the other end of the layer of conductive shielding material 35 either floats or touches the insulating material, if present, surrounding the electrical wire 25.

Although only two adjacent segments of electrical wire 25 and one shielded RF choke 30 are shown in FIGS. 1 and 2, it should be understood that the electrical lead may include multiple adjacent segments of electrical wire 25 and multiple shielded RF chokes 30 connected as shown in FIG. 1 and described above. In fact, in the preferred embodiment of the electrical lead 5, the electrical lead 5 includes a length consisting of multiple adjacent segments of electrical wire 25 and multiple shielded RF chokes 30 provided therebetween. In this preferred embodiment, each segment of electrical wire 25 is substantially shorter than one half of the wavelength of the electromagnetic field with which it is desired to use the electrical lead 5. As will be appreciated, if multiple electromagnetic fields are possible, then the shortest of the wavelengths is chosen for this design parameter. In the most preferred embodiment, each segment of electrical wire 25 is less than or equal to about one quarter of the wavelength ( $\lambda/4$ ) of the electromagnetic field (e.g., the RF field to be used in an MRI scanning process; the most common frequency used in MRI scanning are 64 MHz, although 42 MHz and 128 MHz systems are also common) with which it is desired to use the electrical lead 5. In one embodiment, the preferred electrical lead 5 may be a conventional lead used for implantable devices that is serially modified to include the shielded RF chokes 30 at predetermined intervals such as intervals of at least every  $\lambda/4$ . Alternatively, in another embodiment, the preferred electrical lead 5 may be specially manufactured to include the shielded RF chokes 30 at predetermined intervals such as intervals of at least every  $\lambda/4$ .

As is known in the art, RF chokes resist the flow of currents of certain frequencies and pass currents of certain relatively lower frequencies (the term "RF trap" is also commonly used). Thus, in the electrical lead 5, the shielded RF choke or chokes 30 will resist (and possibly entirely prevent) current flow at high frequencies such as the RF field frequencies of an MRI device, and will at the same time let the current pass at lower frequencies, e.g., the frequencies of the implantable device with which it is used. As a result, the possibility of the induction of current, and therefore production of heat, due to the RF field of the MRI is reduced (and possibly entirely prevented), while still allowing the transmission of signals from a generator 15 to a location 20 as shown in FIG. 2. In the preferred embodiment, the segment of electrical wire 25 that is provided inside the location 20, such as an organ or other tissue, does not include a shielded RF choke 30, and instead is preferably shorter than  $\lambda/2$  and therefore relatively safe.

FIG. 3 is a schematic diagram of an electrical lead 5' according to an alternate embodiment of the present invention

7

that is similar to the electrical lead **5** except that it includes one or more shielded RF chokes **30'** that, instead of using a single layer of shielding material **35**, employ multiple layers of shielding material **35A** and **35B** for improved decoupling of the magnetic field. Preferably, the electrical lead **5'** includes multiple RF chokes **30** spaced at intervals as described. As seen in FIG. **3**, in each layer of shielding material **35A** and **35B**, one end of the layer is electrically connected to the inductor **33** and the other end of the layer either floats or touches the insulating material, if present, surrounding the electrical wire **25**.

FIG. **4** is a schematic diagram of an electrical lead **5"** according to a third, further alternate embodiment of the present invention that is similar to the electrical lead except that it includes one or more shielded RF chokes **30"** in the form of inductors **33** that each have a core **40** provided within the inductor **33**. The core **40** inside each inductor **33** provides a higher inductance for a given resistance. Preferably, a paramagnetic material, such as, without limitation, aluminum or various plastic materials, is used to form the core **40**. Preferably, ferromagnetic materials should not be used for the core **40** to resist any attraction by the magnetic field of the MRI.

FIG. **5** is a schematic diagram of an electrical lead **45** according to a yet another alternate embodiment of the present invention. The electrical lead **45** is similar to the electrical lead **5** shown in FIG. **1** in that it includes a plurality of segments of electrical wire **25**. The electrical lead **45** in this embodiment includes one or more shielded RF chokes **47** each having the form of a toroidal inductor that preferably includes a torus-shaped coil **50** wrapped around a doughnut-shaped core **55**. The shielded RF chokes **47** perform essentially the same function as the shielded RF chokes **30** described above as the shielded RF chokes **47** trap electromagnetic fields within the doughnut-shaped core **55** and resist the induction of currents as a result of external electromagnetic fields. Preferably, the electrical lead **45** includes multiple shielded RF chokes **47** spaced at intervals as described above in connection with the shielded RF chokes **30**. When the shielded RF chokes **47** are used, there may be no need for a layer of shielding material (as in the shielded RF chokes **30**, **30'** and **30"** as the electromagnetic field is trapped inside the core **55**.

FIG. **6A** is a schematic diagram of an electrical lead **60** according to still a further alternate embodiment of the present invention. The electrical lead **60** includes a plurality of segments of electrical wire **25'** which, in this embodiment, each comprise a multiple conductor wire, preferably in the form of a flexible insulated multiple conductor wire or a coaxial cable. The electrical lead **60** is similar to the electrical lead **5** shown in FIG. **1** as it includes a one or more shielded RF chokes **30** including an inductor **33** surrounded by layer of shielding material **35** as described above. Preferably, as shown in FIG. **6B**, the electrical lead **60** includes multiple shielded RF chokes **30** spaced at intervals as described above in connection with FIG. **1**. As seen in FIGS. **6A** and **6B**, a first end of each inductor **33** of each shielded RF choke **30** is electrically coupled to each of the wires of one of the adjacent segments of electrical wire **25'** and the opposite end of the inductor **33** of each shielded RF choke **30** is electrically coupled to each of the wires of the other of the adjacent segments of electrical wire **25'**. In addition, it should be appreciated that, in variations of this embodiment, an additional layer or layers of shielding material may be provided as shown in FIG. **3**, a core **40** may be provided in the shielded RF choke **30** as shown in FIG. **4**, and/or a toroidal RF choke **47** as shown in FIG. **5** may be used.

8

FIG. **7** is a schematic diagram of an electrical lead **60'** according to another alternate embodiment of the present invention that is similar to the electrical lead **60** shown in FIG. **6**. The electrical lead **60'** differs from the electrical lead **60** in that, instead of a single shielded RF choke **30** being provided between adjacent segments of electrical wire **25'**, multiple shielded RF chokes **30** are provided between adjacent segments of electrical wire **25'**. Specifically, as shown in FIG. **7**, one shielded RF choke **30** is provided for each conductor contained in the segments of electrical wire **25'**. FIG. **8** is a schematic diagram of an electrical lead **60"** according to yet another alternate embodiment of the present invention that is similar to the electrical lead **60** shown in FIG. **6** except that each shielded RF choke **30** is replaced by a toroidal shielded RF choke **47** as shown in FIG. **5**.

FIGS. **9A** and **9B** are schematic diagrams of a electrical leads **65A** and **65B**, respectively, according to still further alternate embodiments of the present invention. As seen in FIG. **9A**, the electrical lead **65A** includes a plurality of segments of electrical wire **25'** which each comprise a multiple conductor wire, preferably in the form of a flexible insulated multiple conductor wire. As noted elsewhere herein, the multiple conductor wire or each conductor therein may be, for example and without limitation, a coaxial wire or a triaxial wire. The electrical lead **65A** includes a one or more alternative shielded RF chokes **67A** that are preferably spaced at intervals as described above in connection with FIG. **1**. As seen in FIG. **9A**, each shielded RF choke **67A** comprises a layer of shielding material **35** as described above that covers but is not in contact with the conductor portions **75** located between the adjacent segments of electrical wire **25'**, and a capacitor **70** provided between each such conductor **75** and the layer of shielding material **35**. In addition, in the shielded RF choke **67A**, an inductor **33** is provided between each conductor **75** and the segment of electrical wire **25'** that is electrically upstream (in terms of current flow) from the point at which the capacitor **70** is connected to the conductor **75**. In the embodiment shown in FIG. **9A**, the capacitors **70** are tuned. The electrical lead **65B** shown in FIG. **9B** is similar to the electrical lead **65A**, except that in the electrical lead **65B**, an inductor **33** is provided between each conductor **75** and the segment of electrical wire **25'** that is electrically downstream (in terms of current flow) from the point at which the capacitor **70** is connected to the conductor **75**. In the electrical lead **65B**, the capacitors **70** are short at relatively high frequencies (on the order of 100 MHz) and therefore no signal is transmitted by the electrical lead **65B**, and therefore no signal is provided to the location **20** (such as the brain or some other organ or tissue within the body) shown in FIG. **2**. As an alternative, in either electrical lead **65A** or **65B**, the inductors **33** may be wrapped together.

FIG. **10** is a variation of the embodiment shown in FIG. **6** wherein a layer of insulating material **80**, such as, without limitation, Teflon, polyethylene, nylon, rubber or pvc, is provided around the segments of electrical wire **25'** and the shielded RF chokes **30** except for those areas that must remain exposed for proper operation of the implantable device with which the electrical lead **60** is to be used (as is known, some implantable devices, such as pacemakers, require one or more portions of the leads to be exposed so that an electrical connection or connections to the body can be made). The layer of insulating material **80** will provide further safety as charges may tend to accumulate at the edges of the layer of shielding material **35**. The use of the layer of insulating material **80** is not limited to the electrical lead **60**, but may also be used with the other embodiments shown herein. In addition, when the electrical lead **60** (or the other electrical

leads described herein) are used with an implantable device, the layer of insulating material **80** may also cover the generator **15** (FIG. 2).

A number of simulations of the performance of the electrical lead **5** were performed by the present inventors. The simulation results are depicted in FIGS. 11A and 11B. FIG. 11A shows the normalized induced current on a regular wire and a lead **5**. FIG. 11B shows the SAR distribution on the surface of the regular and the lead **5**. From these simulations, it is obvious that the lead **5** is able to separate the wire into two wires.

In addition, in order to evaluate the effectiveness of the present invention, gel phantom experiments were performed on a regular pacemaker and a pacemaker including an electrical lead **5**. The gel phantom setup is shown in FIG. 12 and includes a temperature probe **1** located at the tip of the pacemaker lead in each case and a reference probe **2**. The gel phantom setup for each pacemaker (regular and safe, i.e., including the lead **5**) shown in FIG. 12 was subjected to MRI scanning and profiles of the temperatures measured by the probes are shown in FIG. 13. As can be seen, the pacemaker that included the lead **5** experienced significantly less heating.

While preferred embodiments of the invention have been described and illustrated above, it should be understood that these are exemplary of the invention and are not to be considered as limiting. Additions, deletions, substitutions, and other modifications can be made without departing from the spirit or scope of the present invention. Accordingly, the invention is not to be considered as limited by the foregoing description but is only limited by the scope of the appended claims.

What is claimed as new and desired to be protected by Letters Patent of the United States is:

1. An implantable lead which resists induction of a current from an electromagnetic field external to the lead, comprising:

a plurality of pairs of adjacent segments of electrical wire, each pair comprising a first segment of electrical wire and a second segment of electrical wire; and

a plurality of RF chokes, each RF choke being provided between, and operatively coupled to, the first segment of electrical wire and the second segment of electrical wire of a respective one of the plurality of pairs of adjacent segments,

wherein each RF choke is configured and arranged to resist current flow at an RF field frequency of a MRI device and pass currents of substantially lower frequency than the RF field frequency of the MRI device.

2. The lead of claim 1, wherein each RF choke comprises an inductor.

3. The lead of claim 2, wherein each RF choke further comprises an electrical shielding material disposed around the inductor.

4. The lead of claim 3, wherein a first end of the electrical shielding material is electrically connected to the inductor.

5. The lead of claim 4, further comprising an insulating material disposed around at least a portion of the adjacent segments of electrical wire, wherein a second end of the electrical shielding material is floating or touches the insulating material.

6. The lead of claim 2, wherein each inductor comprises a core.

7. The lead of claim 2, wherein at least one of the inductors is a toroidal inductor.

8. An implantable stimulation apparatus which resists the induction of a current from an electromagnetic field external to said apparatus, comprising:

a generator for generating one or more electrical pulses; and

the lead of claim 1 coupleable to the generator.

9. The implantable stimulation apparatus of claim 8, wherein the lead is configured and arranged for deep brain stimulation.

10. The implantable stimulation apparatus of claim 8, wherein the apparatus is a neurostimulator.

11. The implantable stimulation apparatus of claim 8, wherein the apparatus is a pacemaker or a cardio defibrillator.

12. An implantable lead which resists induction of a current from an electromagnetic field external to the lead, comprising:

a plurality of pairs of adjacent segments of electrical wire, each pair comprising a first segment of electrical wire and a second segment of electrical wire; and

a plurality of RF chokes, each RF choke being provided between, and operatively coupled to, the first segment of electrical wire and the second segment of electrical wire of a respective one of the plurality of pairs of adjacent segments,

wherein each RF choke is configured and arranged to trap an electromagnetic field within a confined area in order to resist penetration of an external electromagnetic field into the confined area.

13. The lead of claim 12, wherein each RF choke comprises an inductor.

14. The lead of claim 13, wherein each RF choke further comprises an electrical shielding material disposed around the inductor.

15. An implantable stimulation apparatus which resists the induction of a current from an electromagnetic field external to said apparatus, comprising:

a generator for generating one or more electrical pulses having a generator frequency; and

an implantable lead coupleable to the generator, the lead comprising

a plurality of pairs of adjacent segments of electrical wire, each pair comprising a first segment of electrical wire and a second segment of electrical wire; and

a plurality of RF chokes, each RF choke being provided between, and operatively coupled to, the first segment of electrical wire and the second segment of electrical wire of a respective one of the plurality of pairs of adjacent segments,

wherein each RF choke is configured and arranged to resist current flow at an RF field frequency of a MRI device and to pass the electrical pulses from the generator, wherein the generator frequency of the electrical pulses is substantially less than the RF field frequency of the MRI device.

16. The implantable stimulation apparatus of claim 15, wherein the lead is configured and arranged for deep brain stimulation.

17. The implantable stimulation apparatus of claim 15, wherein the apparatus is a neurostimulator.

18. The implantable stimulation apparatus of claim 15, wherein the apparatus is a pacemaker or a cardio defibrillator.

19. The implantable stimulation apparatus of claim 15, wherein each RF choke comprises an inductor.

20. The implantable stimulation apparatus of claim 19, wherein each RF choke further comprises an electrical shielding material disposed around the inductor.